

Dual Scaler Hi-Resolution Mixer Seamless Switcher for Large Screen Projections, Boardrooms and Classrooms.

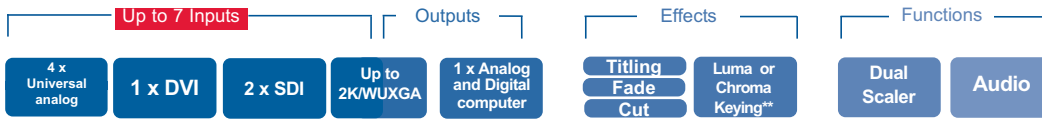

* 1 PIP on Live Background
** On DVI inputs (Only)

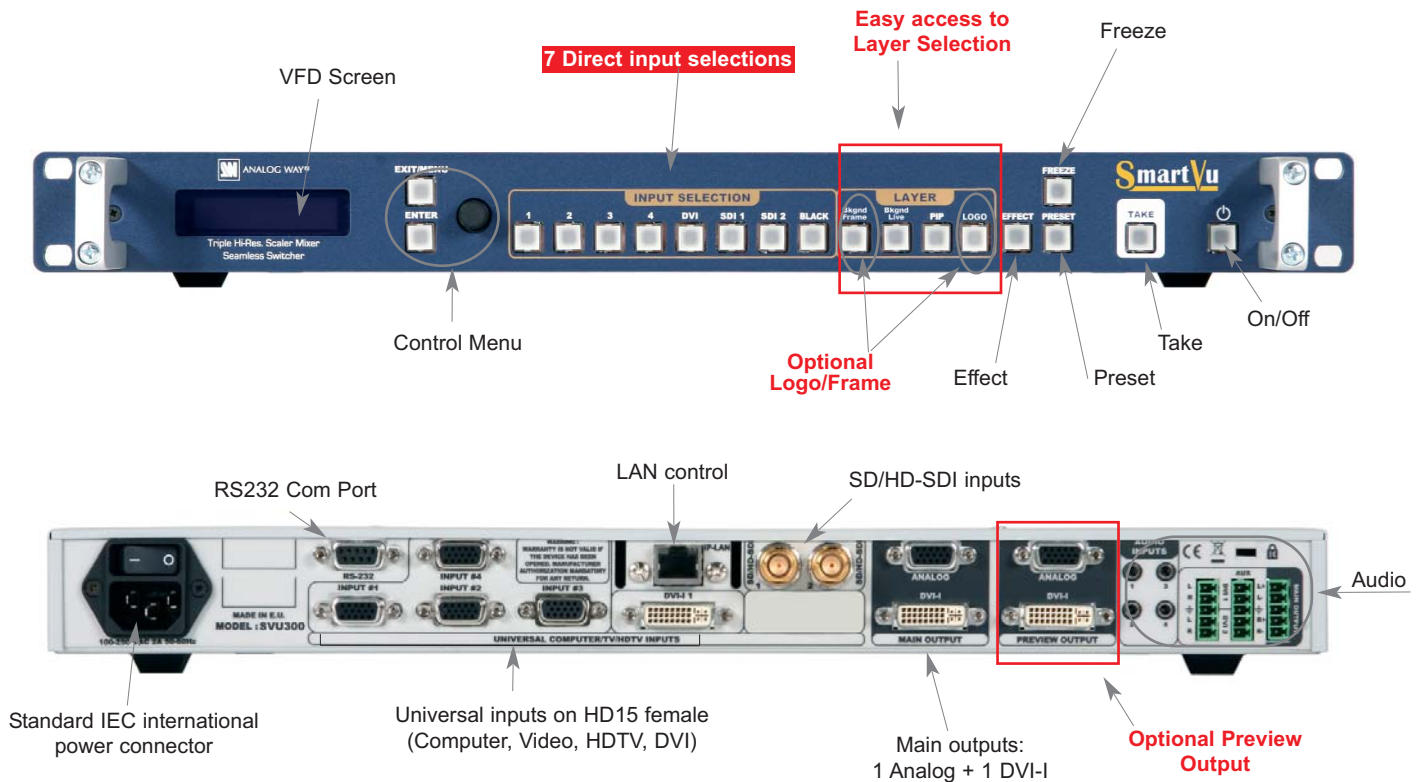

Up to 7 Inputs

- 1 Digital Input (DVI-D)
- 4 Universal Analog Inputs
- 2 SD/HD-SDI Inputs
- SDTV, EDTV, HDTV and Computer formats up to 2K
- Full digital In/Out Processing

Outputs

- 1 Analog and Digital Outputs: Main
- Computer Formats up to 2K
- RGBHV and DVI

Operation Modes & Effects

- Mixer Mode
- Live background and 1 Live PIP
- PIP: Pan & Zoom resizing up to 1000%
- Transitions: Fade (Dissolve), Cut, Wipe & Slide
- PIP Open/Close Animation
- PIP Border (Edge: 1 Color, 1 Width)

Additional Features

- RS232 and Ethernet Port for Control or Upgrade
- Remote Control Software (Supplied)
- Integrated Audio Stereo Switcher with SDI audio de-embedder



Seamless Switchers

Technical Specifications

4 Universal Inputs - Analog Inputs (All inputs #1 to #4) :

SD-TV:

- Composite, S.Video, YUV, RGsB or RGsB
- NTSC: 15.735kHz / 60Hz
- PAL/SECAM : 15.625kHz / 50Hz

ED/HD-TV:

- RGsB, RGsB or YUV
- 480p / 60 Hz – 576p / 50 Hz - 720p, 1080i, 1035i / 50 or 60Hz
- 1080p / 24, 25, 30, 50 or 60 Hz – 1080psF / 24, 25 or 30 Hz

Computer:

- RGBHV, RGsB or RGsB
- Resolution up to 1600x1200 / 60 Hz, 1920x1200 / 60 Hz or 2048x1080 / 60 Hz
- Horizontal frequency from 31.5 to 130 kHz
- Vertical frequency up to 130 Hz
- FpxMax = 165MHz

Digital Inputs (DVI-D 1 and SDI1 and SDI2):

- DVI-D: SD-TV, ED-TV, HD-TV and Computer formats
- SDI: SD-TV & HD-TV – YUV / 10bits / 4:2:2
- Automatic synchronization detection

Main Output:

Computer Digital and Analog:

- RGBHV, RGsB or RGsB and DVI
- Resolution up to 1600x1200 / 60 Hz, 1920x1200 / 60 Hz or 2048x1080 / 60 Hz
- Vertical frequency 50, 60, 72 or 75 Hz depending on Output format
- FpxMax = 165MHz

Audio Stereo In/Out:

Inputs:

- 5 Audio stereo inputs + 1 Auxiliary
- AUX Balanced
- Vi = +15dB max
- Zi = 20 kOhms (Unbalanced) / 40 kOhms (Balanced)
- Adjustable Level per input

Outputs:

- 1 output
- Balanced/Unbalanced
- Vo = +15 dBu / 300 Ohms (Unbalanced)
- Vo = +21 dBu / 600 Ohms (Balanced)

User Controls - Front Panel:

- Standby On/Off
- Input, Layer direct access
- Freeze/Black
- Effect and preset selection
- Graphic VFD screen with control knobs and buttons for Easy and fast access to menus and adjustments

Connectors - Rear Panel:

- **Input #1 to #4 Connectors:**
- HD15-F: (Analog SD/ED/HD-TV and Computer)
- **Input DVI-D 1 Connectors:**
- DVI-I Female: (Analog SD/ED/HD-TV and Computer)
- **Audio:**
- 3.5mm Stereo jack: inputs #1 to #4
- 5 pins MCO connectors: 2 for Inputs and 1 for Output

Output Main:

The output is fitted with:

- DVI-I Female: (Digital and Analog) RGB or YUV
- HD15 Female: RGB or YUV

Connectors - Rear Panel continued

- DB9: two RS232 for remote control
- RJ45: Ethernet connection
- AC main connector with On/Off switch

Dimensions: 1U, 19"

- D 13.8" x W 19" x H 1.74"
- D 350 mm x W 480 mm x H 44 mm

Weight: 5kg / 14.3lbs

Power Supply:

- Internal, universal, automatic, 100-250 V; 50/60 Hz; 100 W (UL, CSA, GS, CE)

Supplied with:

- 1 x AC power cable
- 1 x Remote control software
- 1 x User manual on Cd-Rom
- 1 x Quick Start
- 1 x HD15 to 5 BNC Cable
- 1 x Ethernet cross cable (for update)
- 1 x Set of 3 audio 5-pin screw terminals

Warranty:

3 year warranty on parts and labor back to factory

Specifications subject to change without prior notice

SmartVu by **Analog Way** is a Dual Scaler Mixer Seamless Switcher with Universal Analog and Digital input/output and Full High Resolution Digital Processing. It offers numerous Live effects including Keying and PiP animation.

Mixer Mode:

The **SmartVu** can display up to 2 Live Sources. Live Layers can be customized by the users with various attributes: Borders, Movements, Zoom, Cut, Fade, Wipe & Slide.

General Features:

The **SmartVu** offers up to 7 inputs including 1 fitted with digital DVI and 2 fitted with SDI. SDI is compatible with SD and HD TV formats so is DVI, which offers computer formats in addition. With state of the art 100% digital processing, the **SmartVu** outputs Digital and Analog Signals in DVI and VGA (RGBHV) simultaneously with a selection of many formats up to Computer 2K. **SmartVu** provides a high image quality thanks to its true 10 bits SD/HD auto adaptive pixel by pixel 3D motion compensation processing, de-interlacing, auto 3:2 and 2:2 reverse pull down circuitry and processing and Frame follower.

Integrated Audio Stereo switcher features 7 inputs (5 analog and 2 from embedded SDI) and 1 output. An auxiliary input can be mixed with any other input. Master volume and individual input level can be adjusted. Auxiliary input and output offers balanced or unbalanced connections.

SmartVu is a high grade easy to use A/V Presentation Mixer Switcher particularly adapted to Large Screen Projections, Boardrooms and Classrooms. Fully controlled from its own front panel as well as from Remote Control Software (supplied), it offers a large range of utilization. Equipped with TCP/IP and RS232, **SmartVu** can be updated with new features and functions improving its life time.

References

> **SVU300:** SmartVu

Option

- **OPT-MMS-Preview:** Optional Preview
- **OPT-MMS-Logo:** Optional Logo (4 Logo Memories, 4 Full Frames) (1 Logo + 1 Frame Simultaneously)

To Control SmartVu

> **Remote Control Software (RCS):** Supplied

Cables for SmartVu

- > 0.5m/1ft to 30m/100ft Remote Cables
- > 3m/10ft to 30m/100ft SDI-HD SDI Cables
- > 1.8m/6ft to **60m/197ft** DVI Cables
- > 0.5m/1ft to 1.8m/6ft VGA Cable

ANALOG WAY

USA, Canada, South America and The Carribeans

ANALOG WAY Inc.
Tel. 212 269 1902
Fax. 212 269 1943
Email: salesusa@analogway.com

Europe, Africa and Middle-East

ANALOG WAY FRANCE
Tel. 331 64 47 16 03
Fax. 331 64 47 14 73
Email: saleseuro@analogway.com

Vers: SB-7-10-26-09-SVU300

Asia Pacific

ANALOG WAY Pte Ltd
Tel.: 65 62 92 58 00
Fax.: 65 62 92 52 05
Email: sales@analogwayasia.com