

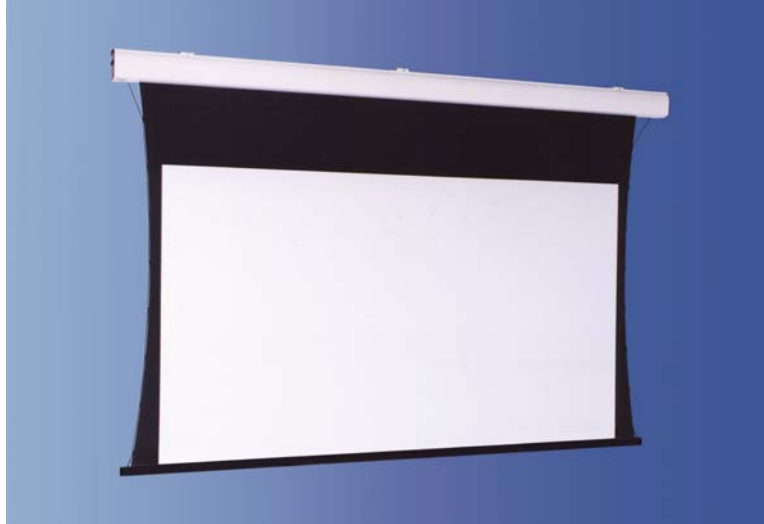

## ELLIPSE LARGE TENSIONED



- Silent motor system provides a smooth and quiet operation
- Totally manufactured in aluminium
- Smart design and easy to install
- Housing dimensions: 124x133 mm.
- Painting treatment with white epoxy powders (RAL 9010)
- Universal mounting brackets either for ceiling or for wall
- Switcher on/off included
- Projection fabrics are flame-retardant, classification M1 and M2
- Side black borders of 5 cm. (in the narrowest point), black drop of 30 cm. on the top and black counterweight (35 mm. high)
- Tensioning system on both sides

Warranty: - 5 years on the motor  
 - 24 months on the other components

### TECHNICAL DETAILS

<b>Format 4:3</b> Viewing area (WxH) (A)	<b>Format 16:9</b> Viewing area (WxH) (A)	Overall dimensions	Front projection cloths	Net weight approx.
cm. 300x225 cm. 350x265	cm. 300x169 cm. 350x197 cm. 400x225	B cm. 339 C cm. 332 B cm. 389 C cm. 382 B cm. 439 C cm. 432	Matte White gain 1.2 Microperforated gain 1.1 Lumi-Grey gain 0.8	Kg. 28 Kg. 32 Kg. 36

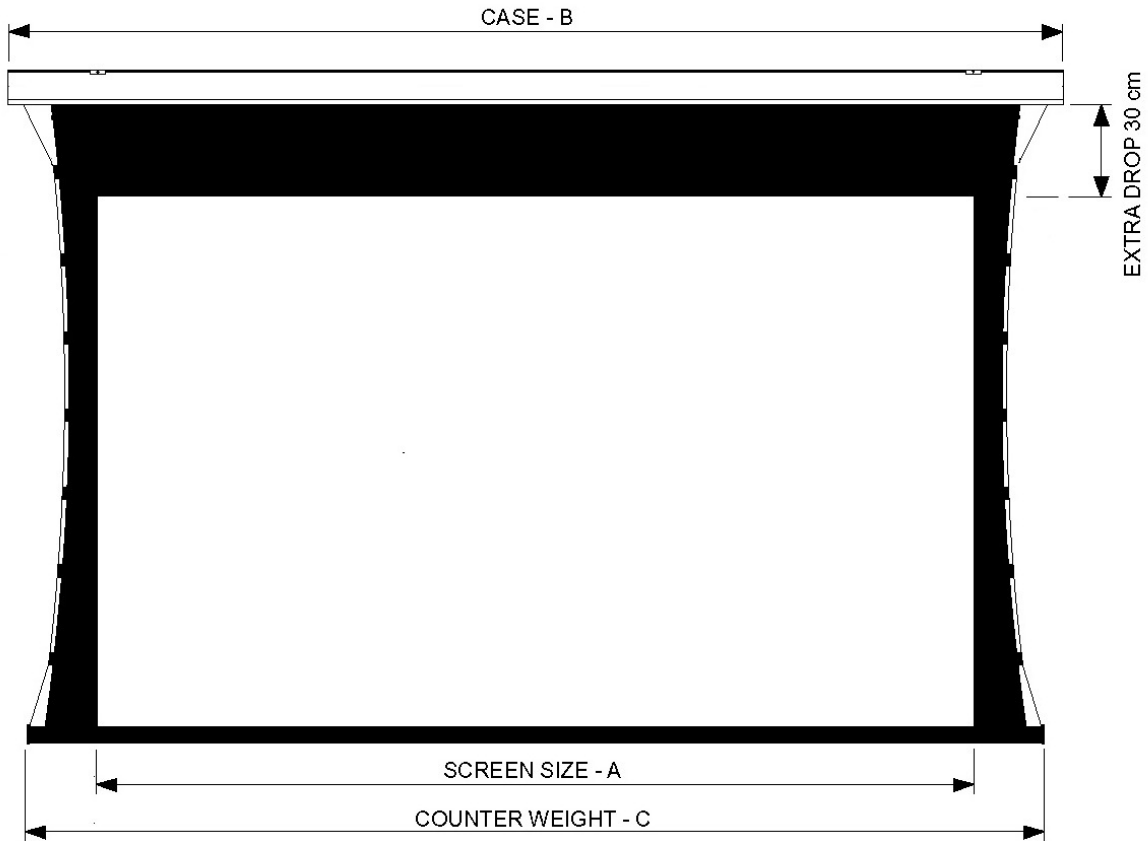

**Concealing counterweight**

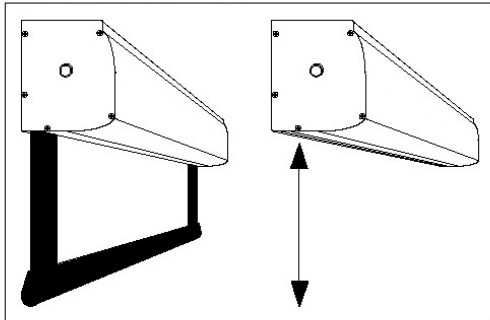

Wall Mounting

**Cabinet dimensions**

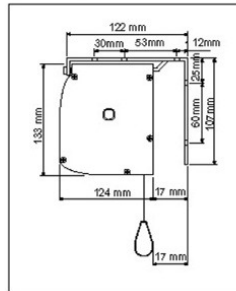

Ceiling Mounting

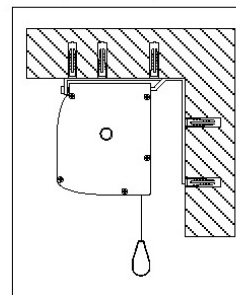
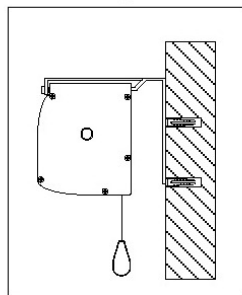

**Motor characteristics**

Power: 8 Nm  
 Speed: 12 rpm  
 Power supply: 230V / 50 Hz  
 Consumption: 90 W  
 Certification: IMQ

Euroscreen S.r.l. has reserved the right to modify the technical characteristics of its products, without obligation of notice and in every time, in order to further improve their performance.

**EUROSCREEN S.R.L.**

Via Stiria, 45/16— 33100 UDINE - Tel. +39 0432 522755 Fax +39 0432 524000  
 Website: [www.screenint.com](http://www.screenint.com) - E-mail: [info@screenint.com](mailto:info@screenint.com)